

QForm 竞赛内容

公司接了一个 30000 件杯型零件的订单。需要开发设计锻造工艺考虑机加工的最小预留量。可以使用下面的设备：

- 液压机 (10MN, 10 mm/s)
- 蒸汽锤 (2 t, 50 kJ)

任务描述

生成一个包含计算并工艺过程和结果的报告，包括工艺的计算和验证，绘图。开发的工艺需要使用 QForm 进行模拟和验证。

技术解决方案的质量、合理性、正确性和选择的方法影响最终评选结果，标准如下：

- 设备的选择（考虑效率和生产力评价，力和能量参数等）
- 锻造工序的选择（考虑材料利用率，变形载荷等）
- 成形模具的开发（考虑模具填充率，成形缺陷少等）

大家有 6 小时来设计工艺，模拟和完成报告。

最后需要生成一个报告文档（使用组委会提供的特别识别号代替姓名），包括报告和最终工艺的 QForm 模拟文件（只需要*.qform 文件，不需要结果）。报告封面和 QForm 文件也需要包含特别识别号（不能带有真实姓名）。

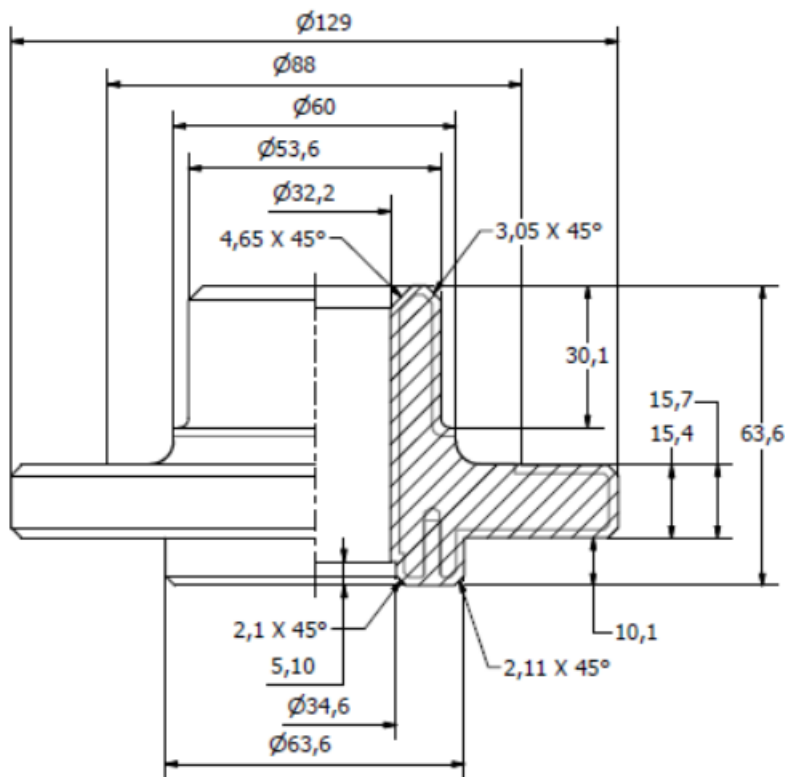

Forging

Task

The company taken an order to produce 30,000 "Coupling" parts. It is necessary to develop the technological process for manufacturing of forgings for further machining taking into account the drawing of the minimum allowances for machining. The following equipment is available:

hydraulic press (10 MN, 10 mm/c)

steam-air hammer (2 t, 50 kJ).

Task notes

Create a report containing the process description and results of performing task including calculations and justification of the proposed technology, applications and drawings in a text file. Simulation should be done in QForm software for estimation and verification of the developed technology.

Quality, reasonability, correctness and chosen approaches of technology problem solving influence on the final mark, taking into account the following criteria:

The final evaluation of the work will be judged taking into account quality, correctness and applied approaches in acceptance of solutions, including the following criteria:

equipment selection (evaluation of efficiency and productivity, force and energy parameters)

selection of forging steps (evaluation of material consumption, deformation load, etc.)

development of die forming cavities (taking into account die cavity filling, lack of stamping defects, etc.)

You have 6 hours to design the technology, to simulate it and to create a report using a text editor.

At the end of the work you have to create an archive (use special number provided by committee) which include a report and a QForm simulation file (without data folder) of a single final process version. The report title and QForm files have to contain your special number too. Do not specify your name and surname.